



The PMC-550D-X Low-voltage Motor Protection and Control Device seamlessly integrates motor protection, control, temperature monitoring with a modular design. Featuring extensive I/O options on the main unit, including 10xDI, 5xDO, 2xRS-485 ports, 1x Analog Output, 1x Residual Current Input, 1x optional PROFIBUS DP, 1x optional PTC Input and 1x optional Analog Output, the device offers flexibility and expandability. Its modular design* allows easy expansion, connecting a standalone HMI module for monitoring and control, and up to 5 expansion modules in total, selectable from PMC-KDIO module with additional 6xDI and 4xDO each and others. The device supports Modbus RTU, with PROFIBUS DP available as an option. Equipped with a robust power supply, it ensures uninterrupted operation for 15 seconds during power interruptions. These versatile features make the device suitable for diverse industrial needs.

Typical Applications

- Low-voltage switchgear
- Industries including Electric power, Petrochemical, Coal, Iron and steel, and Metallurgical as well as Light industry

Motor Control

The PMC-550D-X is a microprocessor-based device that allows users to program and configure its operation through its HMI module, determining appropriate actions based on conditions.

- Voltage Dip Ride-Through: In the event of a short-term voltage dip that causes the AC contactor to drop out, the motor can continue running without a restart process once power is restored.
- Under-Voltage Restart: This control mode is designed to restart a motor accordingly after a voltage dip. It may be either a quick restart, delay restart or stop, depending on the characteristics of the voltage dip.
- Start Interval Control: The PMC-550D-X features functions including Start Control, Stop Control and Start Count Control.
- Local/Remote Control: The PMC-550D-X allows the motor control to be done through the local panel or remote control depending on different control authorities.
- Start Control Modes: The device carries multiple start control modes such as Direct-On-line (DOL) Start, Reduce-Voltage Start, Forward-Reverse Start, Two-Speed Start, VFD-compatible Start, Large Motor Soft Start

Metering and Monitoring

Fundamental Metering

- Line Voltage and Current per Phase
- Voltage and Current Phase Angle
- Voltage and Current Unbalance (%)
- Positive/Negative/Zero Sequence Voltage and Current
- Total kW, kvar, kVA and PF
- Total kWh/kvarh Import/Export
- Thermal Resistance (Ω) and Node Temperature ($^{\circ}\text{C}$)
- IR (Residual Current) and Contactor Coil Current
- System Frequency

Harmonic Metering

- U and I Individual Harmonics from 2nd to 63rd
- Latest motor operating statistics including Trip Current, Trip Times, Start Current, Start Time, Start Counter, Running Time, and Stop Time

Motor Monitoring and Event Logs

- 128 time-stamped logs recording DI/DO status changes, Diagnostic logs and Maintenance events
- 128 time-stamped protection logs recording active protection events with characteristic values
- Start Report stores the latest 64 motor start logs recording Start Control Source, Maximum Start Current, Minimum Start Voltage, Start Time, Time Stamp and Start Result
- Stop Report stores the latest 64 motor stop logs recording Stop Control Source, IA, IB, IC and Timestamp
- 16 Fault Waveform Recordings for specific fault analysis

Commission Test

- Communication Test by synchronizing the sample data to the workstation
- Control Logic Test for the device's DI, DO and Protection Logic without interruption to the running motor

Programmable Logic

- Function Block Diagram (FBD) programming language compliant with IEC 61131-3
- Create Logic control equation with a drag-and-drop text editor via PMC-Designer

Diagnostics

- Correct U & I Phase Sequence
- Inspection of key components such as AD chips and memories during device power-on or operation
- Stator & Rotor fault diagnosis, efficiency & protection action analysis

* In addition, the modular design also includes the PMC-KTMP module with 6 additional NTC inputs for temperature monitoring, the PMC-K2DP module with 1 or 2x DB9 terminals or 4x pluggable terminals for PROFIBUS DP communication, and the PMC-KETH module equipped with 2x Ethernet ports, supporting either Modbus TCP or PROFINET protocols. Please note that mass production for these three expansion modules is scheduled for August 2026.



Low-voltage Motor Protection and Control Device

Motor Protection

Electric motors have distinct electrical and mechanical operation limits. Exceeding these limits may lead to issues such as mechanical vibration, stoppage, thermal damage, and ultimately, motor failure.

Protection Schemes

Electric Fault Protection Startup Timeout, Locked Rotor, Short Circuit, Current Unbalance, Negative Sequence Overcurrent, Undervoltage, Overvoltage, Voltage Unbalance, Zero Sequence Overvoltage, Undervoltage Auto-restart, Ground Fault, Residual Current, Phase Loss, Phase Sequence, MTA Failure, Voltage Sensor Wire Break Alarm, Closing Failure, Contactor (Breaking Capacity), Contactor Failure, Contactor Position Fault Alarm, Emergency Stop Alarm, Motor Thermistor, Thermistor (optional TC1~TC6 on the PMC-KTMP module)

Mechanical Protection tE Time, Block When Start, Overload (Inverse Time), Overload (Definite Time), Underload, Under Power, Reverse Power, Process Interlock Protection (External Fault)

Inputs & Outputs

Digital Input

- Standard 10 channels, either internally wetted @ 24VDC or externally wetted @ 220VAC/DC or externally wetted @ 110VAC/DC
- 6 additional channels per PMC-KDIO module (up to 3 modules), either internally wetted @ 24VDC or externally wetted @ 220VAC/DC or externally wetted @ 110VAC/DC

Digital Output

- Standard 5 channels and 4 additional channels per PMC-KDIO module (up to 3 modules)
- Control and Status Indication

Analog Output

- One or two 4 - 20 mA programmable analog outputs to display the proportional DC signal on an external analog meter or DCS system
- Selectable analog quantity such as Current per Phase and Average, Voltage Average, Total kW, Zero Sequence Current, IR and PLC data, etc.

Optional Thermal Input

- 1 channel PTC Thermistor Input for motor temperature protection
- 6 channels NTC Thermistor Input for critical components, such as switches and contactors inside Low-Voltage PDU compartment for long-term operation if the PMC-KTMP module is equipped (up to 2 PMC-KTMP modules)

Communications

- Standard 2 optically isolated RS-485 ports
- Standard 1xType-C Port for connection between Main Unit and Display Module, supporting Modbus RTU protocol
- Optional 1xPROFIBUS DP port via either DB9 terminal or general terminal and 1xRS-485 port (Modbus RTU)
- Optional 1 or 2xPROFIBUS DP ports per PMC-K2DP module
- Optional 2x10Base-T/100Base-TX Ethernet ports (supporting Modbus TCP or PROFINET) per PMC-KETH module

System Integration

- Supported by our PecStar® iEMS and free configuration software
- Easy integration into other Automation or SCADA systems via Modbus RTU/PROFIBUS DP protocol

Accuracy

Parameters	Accuracy	Resolution
Voltage	±0.5%	0.001V
IA, IB, IC	±0.5%	0.001A
IR	20mA~1200mA: ±1.0%	1mA
	1200mA~5000mA: ±3.0%	
Contactor Coil Current	10mA~1200mA: ±1.0%	1mA
	1200mA~5000mA: ±3.0%	
P, Q	±1.0%	0.001kW/kvar
kWh	±1.0%	0.01kWh
kvarh	±2.0%	0.01kvarh
Power Factor	±1.0%	0.001
Frequency	±0.02Hz	0.01Hz
Analog Output	±0.5%	-
Harmonics	IEC 61000-4-7 Class II	0.01%
Thermal Resistance	1% or 10Ω	0.01Ω
PMC-KTMP NTC Input	0 to 80 °C: ±1.0°C	0.1°C
	80 to 200 °C: ±2.0°C	
PMC-KTMP PTC Input	±1% or 10Ω	0.01Ω
PMC-KTMP PT100 Input	±1°C/1%	0.1°C
PMC-KTMP PT1000 Input	-50~300°C: ±1°C	0.1°C
	300~500°C: ±1.5%	

Terminals Diagram

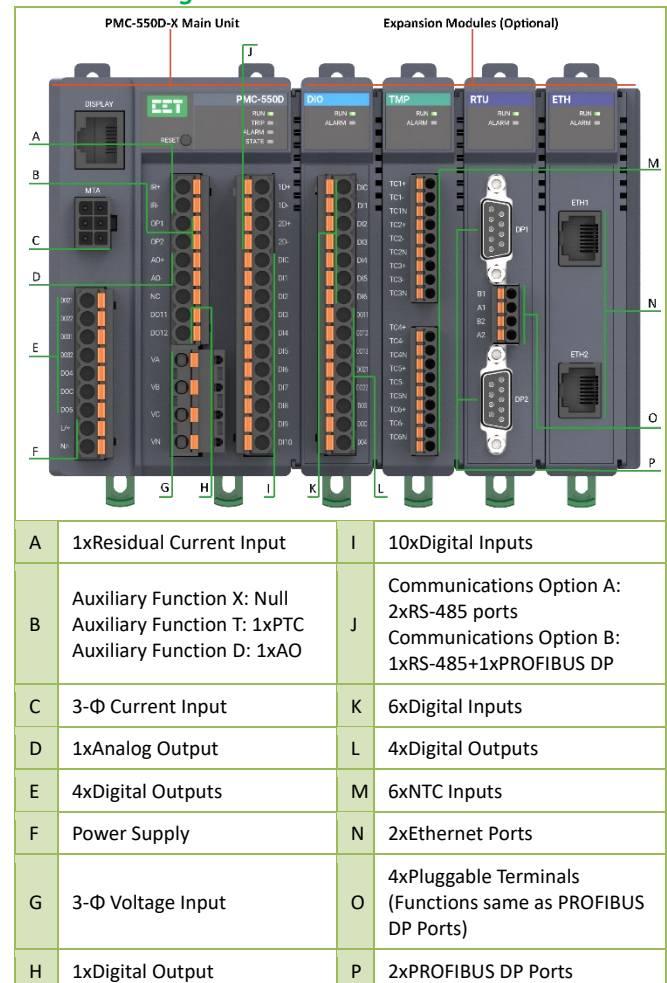



Technical Specifications

PMC-550D-X Main Unit	
Voltage Inputs (VA, VB, VC, VN)	
Nominal (Un)	400VLN/690VLL, 240VLN/415VLL
Range (ULL)	10V to 828V
Burden	<0.75VA/phase
Overload	1.4xUn continuous, 2xUn for 10s
Frequency	50/60Hz
Current Inputs via External Split-Core Current Transducer PMC-MTAs (IA, IB, IC, IN)	
Ie	1A/5A/25A/100A/300A/400A/800A
Range	5% to 120% Ie
Burden	<0.05VA/phase (5A)
Overload	2xIe continuous, 10xIe for 10s, 40xIe for 1s
Residual Current Transducer PMC-MIR (-IR, IR)	
Primary (In)	1A
Secondary	1V
Range	20mA to 5000mA
I _{max}	5In continually
Power Supply (L/+, N/-)	
Standard	95-250V AC/DC ± 10%, with 15 seconds of ride through, 47-440Hz
Burden	<6W
Digital Inputs (DIC, DI1, DI2, DI3, DI4, DI5, DI6, DI7, DI8, DI9, DI10)	
Standard	Internally wetted (Dry contact) with 24VDC
Optional	Externally wetted with 110VAC/DC or 220VAC/DC
Debounce Time	20-9999ms programmable
Digital Outputs (OUT1-OUT5)	
OUT1	
Type	Normally Closed (NC)
Contact Rating	250V AC/30V DC, AC 8A/DC 5A maximum
Breaking Voltage	400V AC/30V DC maximum
Operate Time	<15ms
Release Time	<5ms
OUT2	
Type	Normally Open (NO)
Contact Rating	250V AC/30V DC, 10A maximum
Breaking Voltage	277V AC/30V DC
Operate Time	<8ms
Release Time	<5ms
OUT3-OUT5	
Type	Normally Open (NO)
Contact Rating	250V AC/30V DC, 5A continuous
Breaking Voltage	277V AC/30V DC
Operate Time	<10ms
Release Time	<10ms
Analog Outputs (AO1+, AO1-)	
Type	4-20 mA DC
Loading	750Ω maximum
Thermal Resistance Input (OP1, OP2)	
Type	PTC or NTC
Measurement Range	0.03kΩ to 32.00kΩ
Communications	
RS-485 (Standard)	
Protocol	Modbus RTU
Baud Rate	1200/2400/4800/9600/19200 bps
Data Format	8N2/8O1/8E1/8N1/8O2/8E2
PROFIBUS DP (Optional)	
Protocol	PROFIBUS DP
Baud Rate	9.6/19.2/45.45/93.75/187.5/500/1500 kbps
Environmental Conditions	
Operating Temp.	-25°C to +70°C
Storage Temp.	-40°C to +85°C
Humidity	5% to 95% non-condensing
Atmospheric Pressure	70 kPa to 110 kPa
Altitude	400V: up to 3000m, 690V: up to 2000m
Mechanical Characteristics	
Mounting	DIN Rail
Unit Dimensions	70x83x111 mm
IP Rating	IP30

PMC-550D-X HMI Module	
Display (Power and Communications)	
Power Interface	Max. 100mA, 5VDC
Data Transmission	RJ45 RS-232
Mechanical Characteristics	
Mounting	Panel Mount
Unit Dimensions	106x33.3x70 mm
IP Rating	IP40

Optional PMC-KDIO Module	
Digital Input (DIC, DI1, DI2, DI3, DI4, DI5, DI6)	
Standard	Internally wetted (Dry contact) with 24VDC
Optional	Externally wetted with 110VAC/DC or 220VAC/DC
Debounce Time	20-9999ms programmable
Digital Output (DO11, DO12, DO13, DO21, DO22, DO3, DOC, DO4)	
Type	DO1: Form C Mechanical Relay DO2-DO4: Form A Mechanical Relay
Contact Rating	250V AC/24V DC, 10A maximum
Breaking Voltage	400V AC/300V DC
Breaking Current	0.2A@220VDC, 0.3A@110VDC, 1A@48VDC
Service Life	10,000 cycles (L/R = 40ms) (Electrical at rated load)
Operate Time	<10ms
Release Time	<5ms

Optional PMC-KTMP Module	
TC Input (TC11, TC12, TC21, TC22, TC31, TC32, TC41, TC42, TC51, TC52, TC61, TC62)	
Type	NTC (Optional)
Temp. Meas. Range	0 to 200 °C *
Resistance Range	0.12kΩ to 27.5kΩ
Type	PTC (Optional)
Resistance Range	0.03kΩ to 32.00kΩ
Type	PT100 (Optional)
Temp. Meas. Range	-50 to 200 °C
Type	PT1000 (Optional)
Temp. Meas. Range	-50 to 500 °C

* The maximum withstand temperature of the heat shrink tubing for NTC probe is only 150°C.

Optional PMC-K2DP Module	
PROFIBUS DP (DP1, DP2) or Pluggable Terminals (B1/A1/B2/A2)	
Protocol	PROFIBUS DP
Baud Rate	9.6/19.2/45.45/93.75/187.5/500/1500 kbps #

The maximum baud rate of the enhanced version configuration of PMC-K2DP module is 12 Mbps.

Optional PMC-KETH Module	
Ethernet Ports (ETH1, ETH2)	
Protocol Standard	Modbus TCP, PROFINET 10Base-T/100Base-TX



Low-voltage Motor Protection and Control Device

Dimensions and Installation (Unit: mm)

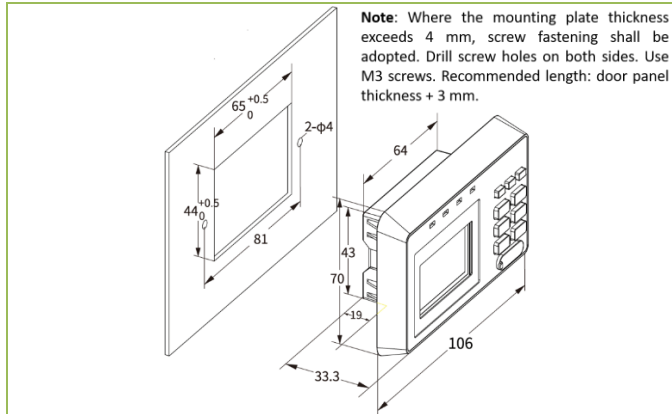

PMC-550D-X Display Module's Panel Installation

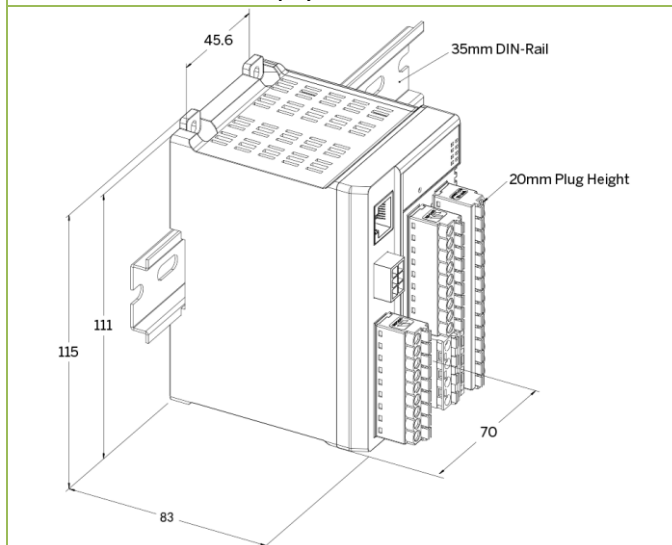

PMC-550D-X Main Unit's 35mm DIN-Rail Installation

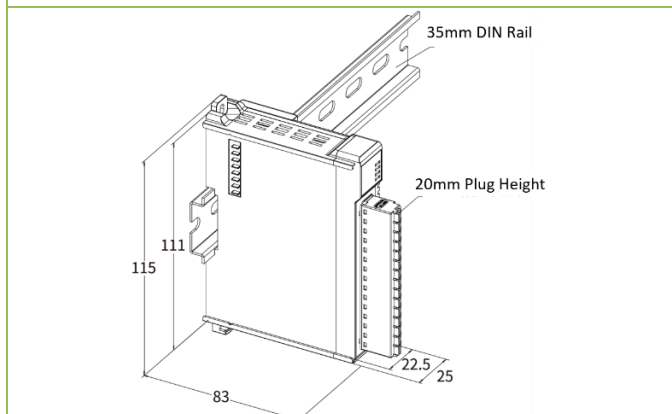

PMC-550D-X Expansion Module's 35mm DIN-Rail Installation

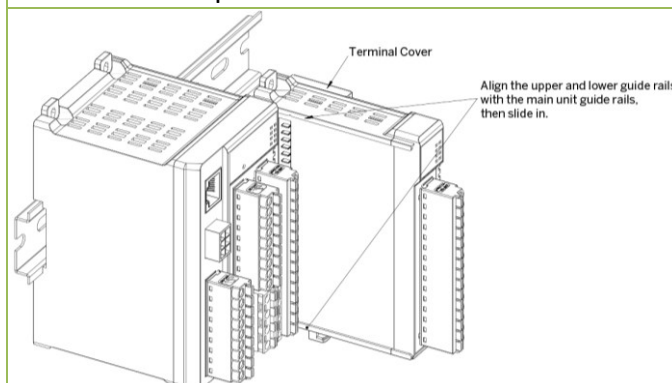

Combined Installation of the Main Unit and Expansion Module

Standards of Compliance

Safety Requirements	
CE LVD 2014 / 35 / EU	EN 61010-1: 2010 + A1: 2019 EN IEC 61010-2-030: 2021 + A11: 2021
Electrical Safety in Low Voltage Distribution Systems up to 1000VAC and 1500VDC	IEC 61557-12: 2021 (PMD)
Insulation	IEC 60255-5: 2000 EN 61010-1: 2010 + A1: 2019
AC Voltage: 2kV @ 1 minute Insulation Resistance: >100MΩ Impulse Voltage: 5kV, 1.2/50μs	
Electromagnetic Compatibility CE EMC Directive 2014 / 30 / EU (EN IEC 61326: 2021)	
Immunity Tests	
Electrostatic Discharge	EN 61000-4-2: 2009 Level IV
Radiated Fields	EN IEC 61000-4-3: 2020 Level III
Fast Transients	EN 61000-4-4: 2019 Level IV
Surges	EN 61000-4-5: 2014 + A1: 2017 Level IV
Conducted Disturbances	EN 61000-4-6: 2014 + AC: 2015 Level IV
Power Frequency Magnetic Fields	EN 61000-4-8: 2010 Level V
Pulsed Magnetic Fields	EN 61000-4-9: 2001 Level V
Damped Oscillatory Magnetic Fields	EN 61000-4-10: 2016 Level V
Voltage Dips and Interruptions	EN IEC 61000-4-11: 2020 Level III
Ripple on DC Input Power Port	IEC 61000-4-17: 2002 Level IV
Damped Oscillatory Wave	EN 61000-4-18: 2011 Level III
Power Frequency Immunity on Binary Inputs	IEC 60255-26: 2023 Class A
Gradual Shut Down / Start-up Tests	IEC 60255-26: 2023 Class A
Immunity Standard for Industrial Environments	EN IEC 61000-6-2: 2019
Emission Tests	
Limits and Methods of Measurement of Electromagnetic Disturbance Characteristics of Industrial, Scientific and Medical (ISM) Radio-Frequency Equipment	EN 55011: 2016 + A1: 2017 + A11: 2020 + A2: 2021
Electromagnetic Compatibility of Multimedia Equipment - Emission Requirements	EN 55032:2015 + AC: 2016 + A11: 2020 + A1: 2020
Limits for Harmonic Current Emissions for Equipment with Rated Current ≤16A	EN IEC 61000-3-2: 2019 + A1: 2021
Limitation of Voltage Fluctuations and Flicker in Low-Voltage Supply Systems for Equipment with Rated Current ≤16A	EN 61000-3-3: 2013 + A1: 2019 + A2: 2021
Emission Standard for Industrial Environments	EN IEC 61000-6-4: 2019
Mechanical Tests	
Vibration Test (Response/Endurance)	IEC 60255-21-1: 1988 Level I
Shock Test (Response/Endurance)	IEC 60255-22-1 Level I
Bump Test (Response Endurance)	IEC 60255-22-1 Level I



Ordering Information

PMC-550D-X Main Unit

Product Code		Description
PMC-550D-X		Low-voltage Motor Protection and Control Device
Language		
E	English	
Input Voltage		
6	400V LN/690V LL	
Power Supply		
A	95-250V AC/DC ± 10%, with 15 seconds of ride through	
System Frequency		
5	50Hz	
6	60Hz	
DI/DO		
N	10xDI (Dry Contact), 5xDO	
2	10xDI (220VAC/DC), 5xDO	
1	10xDI (110VAC/DC), 5xDO	
AO		
A	1xAnalog Output (4-20mA DC)	
Communications		
A	2xRS-485 Port (Modbus RTU, Expansion Module Not Supported)	
B*	1xRS-485 Port (Modbus RTU) + 1xPROFIBUS DP Port (2 Position Terminal Block)	
Auxiliary Function*		
X	None	
T*	1xPTC (PTC Sensor Not Included)	
D*	1xAnalog Output (4-20mA DC)	
HMI		
B	Standard Display Module	
H*	Color LCD Module	
PMC-550D-X - E 6 A 5 N A A X - B		PMC-550D-X-EGASNAAX-B (Standard Model)

*Additional charges apply
 *Expansion Modules and Auxiliary Function are only supported when the Communication Option is selected as "B".
 1. The 3-phase Current Input requires an external MTA Current Transducer. Refer to the MTA Current Transducers sheet for detailed information.
 2. Residual Protection requires an external I Residual CT. Refer to the MIR Current Transducers for detailed information.
 3. For the [I/O] options, default by following:
 • DO1=Normally Closed, DO2-DO5=Normally Open;
 • AO with Internal 24VDC Power Supply.
 4. The PMC-550D-X supports up to 5 expansion modules in total, selectable from: up to 3x PMC-KDIO modules, 1x PMC-K2DP module, 1x PMC-KETH module, and up to 2x PMC-KTMP modules. Refer to the Expansion Modules sheets for full specifications.

Motor Current Transducer (MTA)

Motor Current Transducer (MTA)						
Material Number	Model Number	Motor Rated Power (380V system)	Motor Rated Current (Ie) Range	Aperture (mm)	Cable Type	MTA Type
180007998	PMC-MTA-1A (1x3-Phase)	< 0.4kW	0.1 - 1.2 A	10	1x3-P Cable	3-P Moulded Case
180007999	PMC-MTA-5A (1x3-Phase)	0.4 - 2.2kW	0.5 - 6.0 A	10	1x3-P Cable	3-P Moulded Case
180006371	PMC-MTA-25A (1x3-Phase)	2.2 - 12.5kW	2.5 - 30.0 A	20	1x3-P Cable	3-P Moulded Case
180006372	PMC-MTA-100A (1x3-Phase)	12.5 - 50kW	20.0 - 120.0 A	30	1x3-P Cable	3-P Moulded Case
180006373	PMC-MTA-300A (1x3-Phase)	50.0 - 150kW	60.0 - 360.0 A	30	1x3-P Cable	3-P Moulded Case
180006374	PMC-MTA-600A-T (3x1-Phase)	120 - 200kW	80.0 - 480.0 A	55	3x1-P Cable	1-P Moulded Case
180006375	PMC-MTA-800A-T (3x1-Phase)	160 - 400kW	160.0 - 960.0 A	75	3x1-P Cable	1-P Moulded Case
Current Transducers Accessories						
Material Number	Model Number	Application Range	Description			
190012062	3-P MTA Dedicated Cable	3-P Moulded Case MTA for PMC-550A	1.2m, 3-Phase MTA can be connected through this cable			
190012064	3-P MTA Dedicated Cable	3-P Moulded Case MTA for PMC-550A	2m, 3-Phase MTA can be connected through this cable			
190010521	3-P MTA Dedicated Cable	3-P Moulded Case MTA for PMC-550A	4m, 3-Phase MTA can be connected through this cable			
190012063	1-P MTA Dedicated Cable	1-P Moulded Case MTA for PMC-550A	1.2m, 3x1-Phase MTA can be connected through this cable			
190012065	1-P MTA Dedicated Cable	1-P Moulded Case MTA for PMC-550A	2m, 3x1-Phase MTA can be connected through this cable			
190010806	1-P MTA Dedicated Cable	1-P Moulded Case MTA for PMC-550A	4m, 3x1-Phase MTA can be connected through this cable			

1. Additional charges apply for Motor Current Transducers (MTA) and Cables.
 2. The Motor Power mentioned is based on a 380V system. For other voltages, please use a suitable multiplier based on the actual system voltage (e.g. for a 415V rated motor, multiply the suggested figure by 415/380=1.092).
 3. The required type and quantity of MTA Connection Cables must be ordered separately.
 4. The standard 2m cable is recommended to use with the MTA and can be ordered using the corresponding Group Number. For custom cable lengths, please refer to the "General Accessories for PMC-550 Series Ordering Guide".

Motor Residual Current Transducer (MIR)

Motor Residual Current Transducer (MIR) - For Cable				
Material Number	Model Number	Motor Power (380V system)	Phase Current	Aperture (mm)
180007788	PMC-MIR-35	0.55 - 7.5kW	0 - 63A	35
180007790	PMC-MIR-50	7.5 - 22kW	63 - 125A	50
180007792	PMC-MIR-75	22 - 150kW	125 - 250A	75
180007786	PMC-MIR-120	>150kW	250 - 1000A	120
Motor Residual Current Transducer (MIR) - For Busbar				
Material Number	Model Number	Aperture (mm)	External Dimension (mm)	
180006364	PMC-MIR-265*103	265*103	307*211*60	
MIR-265*103 Connection Cable				
Material Number	Model Number	Description		
190005193	MIR-265*103CC	4m connection cable for MIR-265*103		

1. Additional charges apply for Motor Residual Current Transducers (MIR) and Cables.
 2. Connection cables are included with the MIR-35, MIR-50, MIR-75 and MIR-120. For MIR-265*103, please order the connection cable separately.
 3. The Material number of MIR-265*103 and the connection cable is 180013179.
 4. The standard cable length for both "Cable" and "Busbar" type MIR is 4m. Please contact CET for special requirements.
 5. The Specified Motor Power is based on a 380V system. For other voltage systems, please use a suitable multiplier based on the actual system voltage (e.g. for a 415V rated motor, multiply the suggested figure by 415/380=1.092).

PMC-KDIO Module

Product Code		Description
PMC-KDIO		DI/DO Expansion Module
Language		
E	English	
Configuration		
6DI4DO	6xDI + 4xDO	
DI/DO Type		
N	6xDI (Dry Contact), 4xDO^	
2	6xDI (220VAC/DC), 4xDO^	
1	6xDI (110VAC/DC), 4xDO^	
PMC-KDIO- E 6DI4DO N		PMC-KDIO-E6DI4DON (Standard Model)

^ Among the 4xDO, DO1 has three terminals. For DO1, the connection between DO11 and DO12 is normally open, while the connection between DO12 and DO13 is normally closed. DO2-DO4 are all normally open.
 1. The PMC-KDIO module is powered by the PMC-550D-X main unit, and there is no need for an external power supply.

PMC-K2DP Module

Product Code		Description
PMC-K2DP		PROFIBUS DP Expansion Module
Language		
E	English	
PROFIBUS DP Channel		
1	Single channel	
2	Dual channels	
Scheme Configuration~		
B	Standard Version	
P*	Enhanced Version	
PMC-K2DP- E 2 B		PMC-K2DP-E2B (Standard Model)

* Additional charges apply
 ~ The maximum baud rate supported by the standard version configuration is 1.5 Mbps, while that of the enhanced version configuration is 12 Mbps.
 1. The PMC-K2DP module is powered by the PMC-550D-X main unit, and there is no need for an external power supply.

PMC-KETH Module

Product Code		Description
PMC-KETH		Ethernet Expansion Module^
Language		
E	English	
Protocol		
TCP	Modbus TCP~	
PNT*	PROFINET	
Scheme Configuration		
B	Standard Version	
P*#	Enhanced Version	
PMC-KETH- E TCP B		PMC-KETH-ETCPB (Standard Model)

* Additional charges apply
 ^ The PMC-KETH is equipped with two 10Base-T/100Base-TX Ethernet Ports.
 ~ The Ethernet interface with Modbus TCP protocol supports two network topologies: independent dual-network mode and switch mode, with up to 4 simultaneous TCP client connections
 # The "P (Enhanced Version)" option under Scheme Configuration is only available when Protocol Model is set to "PNT". The enhanced version additionally supports IRT, MRP, and S2 redundancy features.
 1. The PMC-KETH module is powered by the PMC-550D-X main unit, and there is no need for an external power supply.

Your Local Representative

